

EM-3

DISCONTINUED

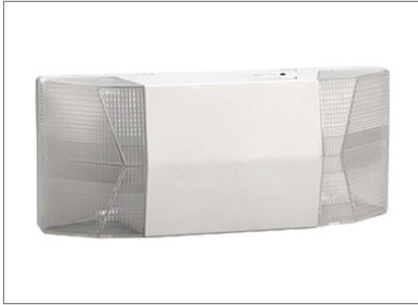

FEATURES:

- Injection-molded, engineering grade, 5VA flame retardant, high-impact resistant, thermoplastic in white or black housing.

MOUNTING:

- Universal knockout pattern on back plate for wall mount. Snaps into place making internal electrical connections.

ELECTRICAL:

- 120V/277V 60Hz dual voltage operation standard.
- Charge rate/power "ON" LED indicator light and push-to-test switch for mandated code compliance testing.
- LVD (Low Voltage Disconnect) prevents battery from deep discharge.

LAMPS:

- Two fixed optics 5.4W glare-free lamp heads.
- Smooth thermoplastic reflector and plastic lens.

BATTERY:

- Maintenance-free, rechargeable 6V 4.5Ah, sealed lead-acid battery on emergency (EM) units.
- Fully automatic solid-state, two-rate charger initiates battery charging to recharge a discharged battery in 24 hours.
- Internal solid-state transfer switch automatically connects the internal battery to LEDs for minimum 90 minute emergency illumination.

LISTING:

- 5 years limited warranty on materials and all electronics. Battery pro rated for two years.
- Meet UL924, NFPA 101 Life Safety Code, NEC, OSHA, Local and State Codes.
- ETL listed for damp locations.

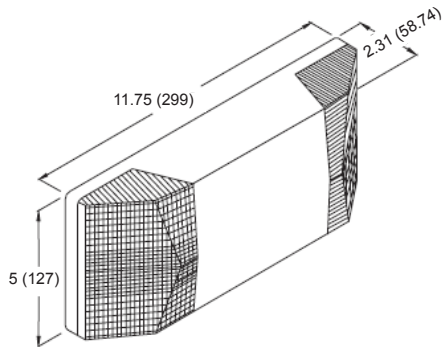

Dimensions

- A: Housing Width: 11.75 (299)
- B: Housing Height: 5 (127)
- *** Housing Depth: 2.31 (58.74)

All dimensions are in inches (millimeters).

ORDERING INFORMATION

EXAMPLE: EM-3-WH

MODEL	HOUSING COLOR	OPTIONS
EM-3	WH White Housing BK Black Housing	WG-1 Steel Wire Guard (13.5" x 15" x 6") BGR-1 Polycarbonate Vandal Shield Guard (7.5" x 18" x 5")